

6Pxx-A1C Six Bolt Composite Disc Coupling

Installation Instructions For Double-Flex A1C Clamp Hub Composite Disc Couplings



TOOLS REQUIRED

- Calibrated torque wrench
 - Hex socket set
 - Shaft alignment tools
 - Cleaning cloth
 - Caliper
- These instructions are for standard series couplings with normal running conditions. Special couplings may have different instructions or drawings.
 - When initially mounting the coupling, the misalignment may be one and one half times the maximum permissible misalignment shown in the catalog. Inspect hub bores, shafts, and keyways making sure there are no burrs. Clean hub bores and shafts. Standard CD coupling hubs are supplied with slight clearance fit (see catalog).
 - Install the coupling onto the shafts. It is recommended that the ends of both shafts be flush with the end of each hub. At the minimum each shaft should extend past the hub clamp slot and extend into one third of the hub flange (non-slotted) area. If the shaft extends past the hub face verify there is enough clearance between shaft and disc pack and the shaft will not contact the disc pack during operation. Tighten one clamp hub socket head cap screw to lock the hub onto the shaft. See the Table on page 2 for the proper tightening torque.
 - Adjust hub separation to dimension “C” specified in the Table on page 2. Tighten second hub to the shaft. See the Table on page 2 for the proper tightening torque.

- Align the shafts within the limits for parallel and angular misalignment specified on page two. For best alignment results, use a laser alignment tool or dial indicator. If not available, a straight edge and feeler gauges can be used.

Note: Aligning the shafts as closely as possible at the time of initial installation will reduce noise and allow the coupling extra capacity for misalignments and loads which will occur during operation over the life of the connected equipment. Installing and operating coupling at higher degrees of misalignment is possible (see catalog ratings), but will generally reduce the life of the composite disc pack.

Note: Coupling and shaft alignment should be checked periodically due to foundation settling, equipment shifting, etc. Alignment should be re-checked after the first several hours of operation.

⚠ Caution: Rotating equipment is potentially dangerous and should be properly guarded. It is the responsibility of the machine builder, user, or operator to follow all applicable safety codes and provide a suitable guard. Make sure the machine is “locked out” and cannot be accidentally started during installation or maintenance of coupling.

6Pxx-A1C Six Bolt Composite Disc Coupling

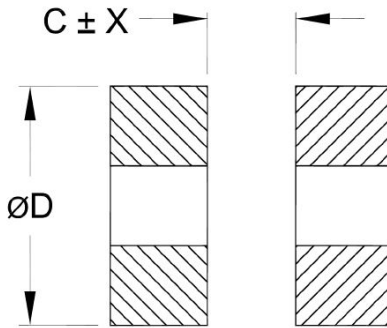
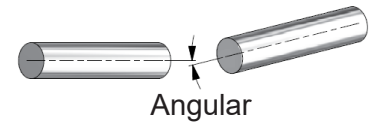
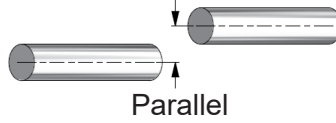
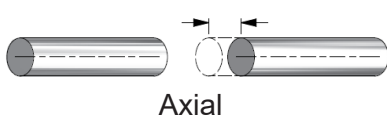

DIAGRAM 1
CHECK HUB SEPARATION

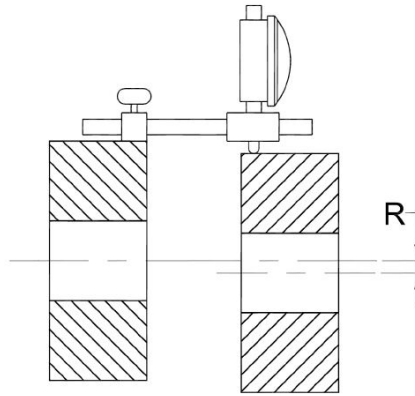

DIAGRAM 2
CHECK PARALLEL MISALIGNMENT

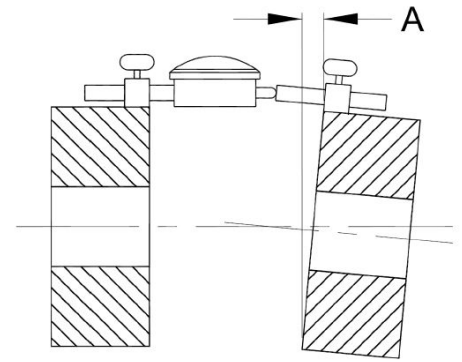

DIAGRAM 3
CHECK ANGULAR MISALIGNMENT

Table 1: Alignment and Assembly Specifications for Double-Flex A1C Couplings.

| Model | $C \pm X$ | R | A | | HUB SPROCKET HEAD CAP SCREW | | DISC PACK SOCKET HEAD CAP SCREW | |
|----------|-----------------------------------|-----------------|-----------------------|----------------------|-----------------------------|-----------------------|---------------------------------|-----------------------|
| | Axial Separation and Misalignment | | Parallel Misalignment | Angular Misalignment | | Tightening Torque | | Tightening Torque |
| | Inch (mm) | Inch (mm) | Inch (mm) | Angle | Wrench Size | | Wrench Size | |
| 6P18-A1C | 0.708 ± 0.20 (18.00 ± 0.50) | 0.011 (0.28) | 0.048 (1.2) | 1.34° | 5mm | 115 in-lb (13 Nm) | 2.5mm | 18 in-lb (214 Ncm) |
| 6P22-A1C | 0.906 ± 0.024 (23.00 ± 0.60) | 0.014 (0.35) | 0.058 (1.4) | 1.34° | 5mm | 115 in-lb (13 Nm) | 4mm | 50 in-lb (564 Ncm) |
| 6P26-A1C | 0.867 ± 0.030 (22.02 ± 0.76) | 0.014 (0.35) | 0.064 (1.6) | 1.34° | 6mm | 283 in-lb (32 NM) | 4mm | 50 in-lb (564 Ncm) |
| 6P30-A1C | 1.340 ± 0.034 (34.03 ± 0.86) | 0.022 (0.56) | 0.076 (1.9) | 1.34° | 8mm | 43 ft-lb (59 Nm) | 5mm | 95 in-lb (10.7 Nm) |
| 6P37-A1C | 1.654 ± 0.046 (42.01 ± 1.16) | 0.028 (0.71) | 0.092 (2.3) | 1.34° | 10mm | 73 ft-lb (99 Nm) | 6mm | 230 in-lb (26 Nm) |
| 6P45-A1C | 1.889 ± 0.060 (47.97 ± 1.52) | 0.032 (0.81) | 0.104 (2.6) | 1.34° | 14mm | 180 ft-lb (245 Nm) | 8mm | 38 ft-lb (51 Nm) |

Note: The above misalignment specifications are recommended values for installation. They allow for extra capacity from operation over time. Refer to the catalog for maximum allowable misalignment specifications.

